

# SRCAGP

COMPUERTA CON LAMAS CON MOVIMIENTO OPUESTO, CON PIVOTE PARA SERVOMANDO



## CARACTERÍSTICAS:

Compuertas cortafuegos con marcado CE certificadas UNI EN 15650 clasificadas según UNI EN 13501-3 y ensayadas según UNI EN 1366/2. Se pueden instalar en conductos de ventilación y garantizan una rápida interrupción del flujo de aire en caso de incendio.

Accionado con electroimán o fusible térmico de rearme mecánico.

## ESTRUCTURA:

Carcasa de acero galvanizado con corte térmico intermedio.

Pala de fibrosilicato accionada sobre pivotes de rotación de acero alojados en casquillos de latón.

Provistas de brida externa para su conexión a los conductos y de dispositivo de desconexión térmica calibrado de serie a 72 °C.

## CONDICIONES DE FUNCIONAMIENTO:

Aire limpio, velocidad máxima 10 m/s.

## DIMENSIONES:

### DIBUJOS

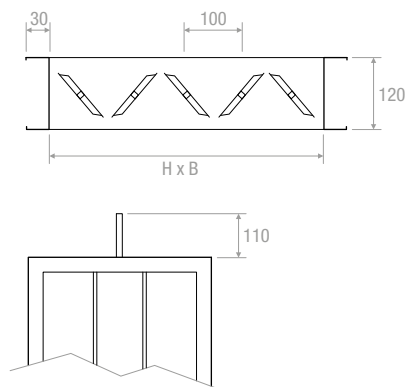

## ACCESORIOS

### MANDO MANUAL

Código - Code: **CM30**

H mm	BASE B mm
210	900
310	1000
410	1100
510	1200
610	1300
710	1400
810	1500
910	
1010	
1110	
1210	
1310	
1410	
1510	
1610	
1710	
1810	
1910	
2010	



ESTANQUEIDAD AL AIRE DE LAS LAMAS

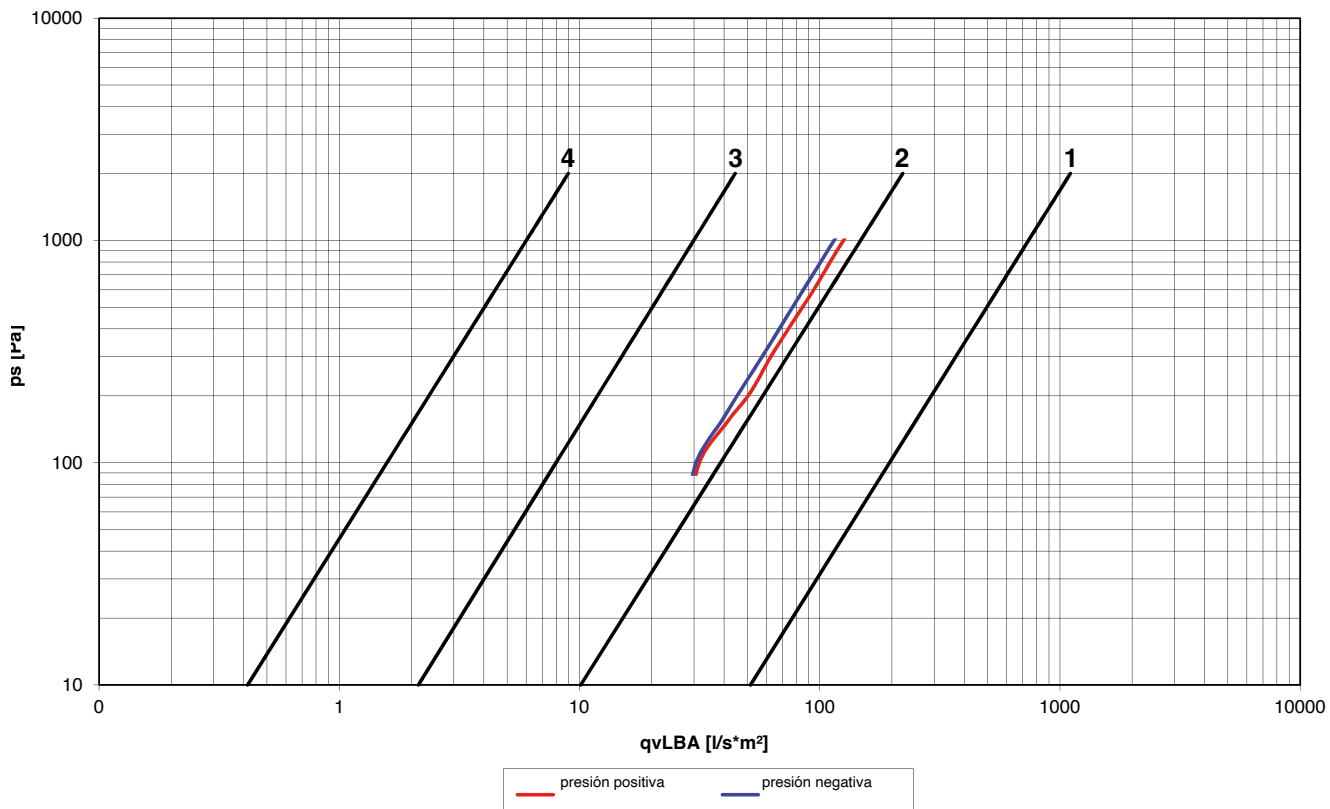

ESTANQUEIDAD AIRE DEL BASTIDOR

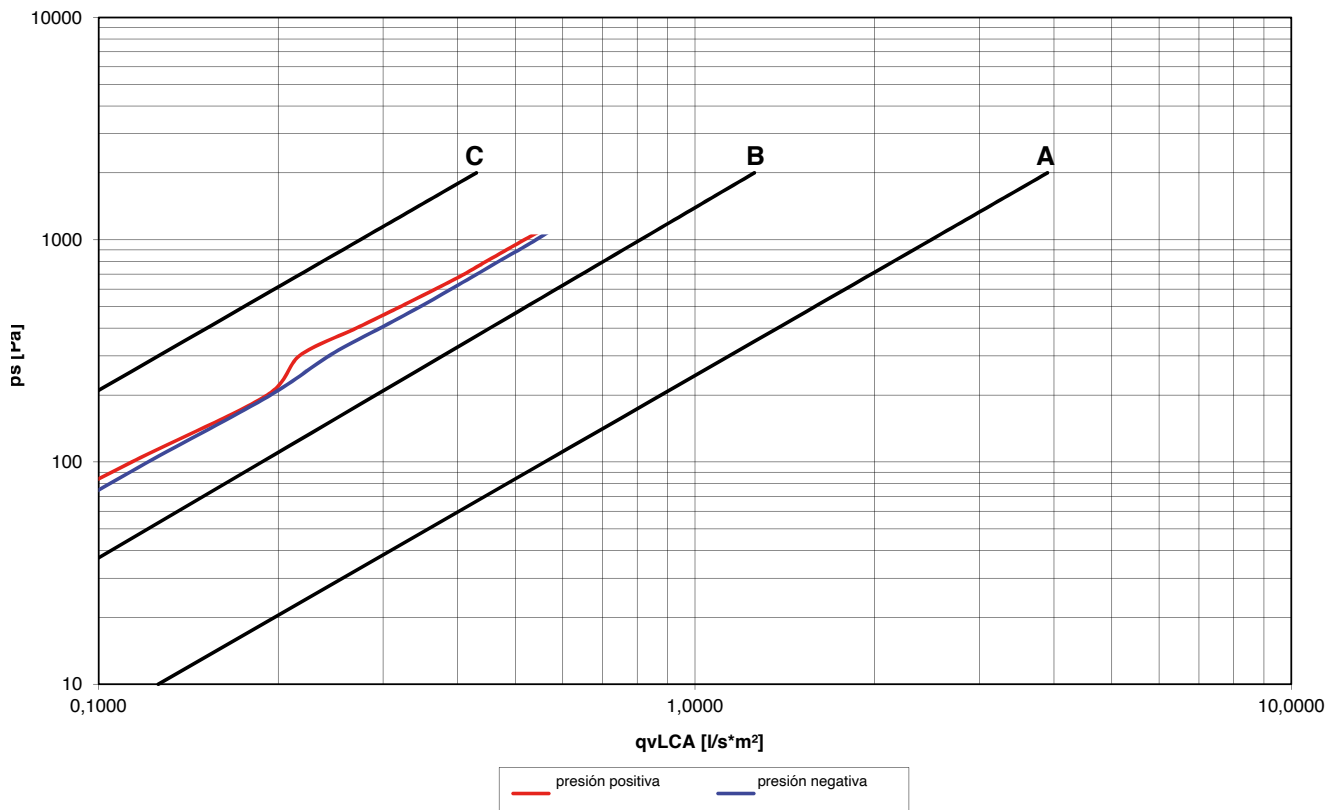

## DIAGRAMA SELECCIÓN RÁPIDA

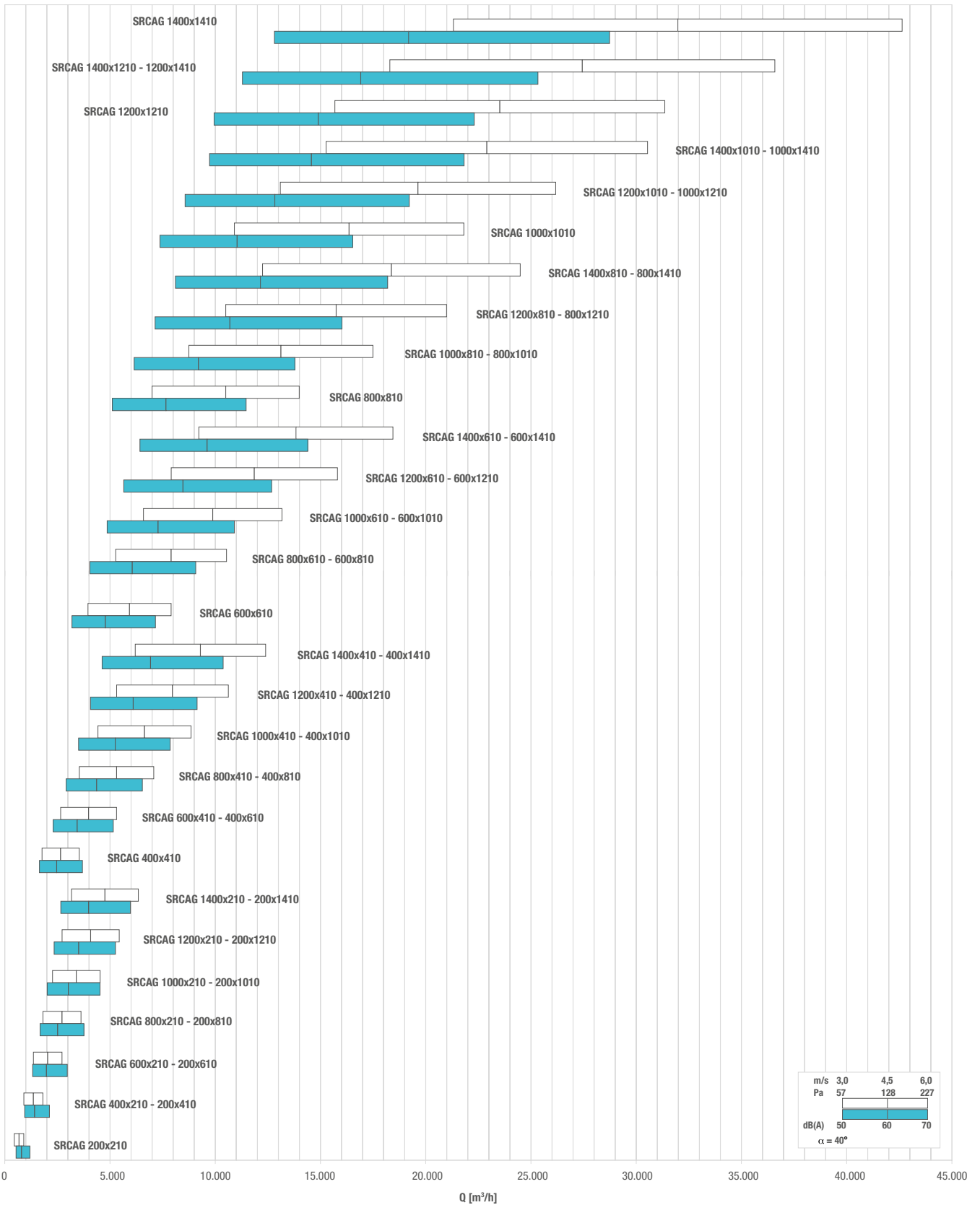

TABLA DE SELECCIÓN

Modelo	A <sub>1</sub> [m <sup>2</sup> ]	v [m/s]		Q [m <sup>3</sup> /h]		Dp (α=40°) [Pa]		L <sub>wa</sub> (α=40°) [dB(A)]	
		min	max	min	max	min	max	min	max
SRCAG 200x210	0,0420	3	6	450	910	57	227	46	63
SRCAG 400x210 - 200x410	0,0840	3	6	910	1810	57	227	49	66
SRCAG 600x210 - 200x610	0,1260	3	6	1360	2720	57	227	51	68
SRCAG 800x210 - 200x810	0,1680	3	6	1810	3630	57	227	52	69
SRCAG 1000x210 - 200x1010	0,2100	3	6	2270	4540	57	227	53	70
SRCAG 1200x210 - 200x1210	0,2520	3	6	2720	5440	57	227	54	71
SRCAG 1400x210 - 200x1410	0,2940	3	6	3180	6350	57	227	54	71
SRCAG 400x410	0,1640	3	6	1770	3540	57	227	52	69
SRCAG 600x410 - 400x610	0,2460	3	6	2660	5310	57	227	54	71
SRCAG 800x410 - 400x810	0,3280	3	6	3540	7080	57	227	55	72
SRCAG 1000x410 - 400x1010	0,4100	3	6	4430	8860	57	227	56	73
SRCAG 1200x410 - 400x1210	0,4920	3	6	5310	10630	57	227	57	74
SRCAG 1400x410 - 400x1410	0,5740	3	6	6200	12400	57	227	57	74
SRCAG 600x610	0,3660	3	6	3950	7910	57	227	55	72
SRCAG 800x610 - 600x810	0,4880	3	6	5270	10540	57	227	57	74
SRCAG 1000x610 - 600x1010	0,6100	3	6	6590	13180	57	227	58	75
SRCAG 1200x610 - 600x1210	0,7320	3	6	7910	15810	57	227	58	75
SRCAG 1400x610 - 600x1410	0,8540	3	6	9220	18450	57	227	59	76
SRCAG 800x810	0,6480	3	6	7000	14000	57	227	58	75
SRCAG 1000x810 - 800x1010	0,8100	3	6	8750	17500	57	227	59	76
SRCAG 1200x810 - 800x1210	0,9720	3	6	10500	21000	57	227	60	77
SRCAG 1400x810 - 800x1410	1,1340	3	6	12250	24490	57	227	60	77
SRCAG 1000x1010	1,0100	3	6	10910	21820	57	227	60	77
SRCAG 1200x1010 - 1000x1210	1,2120	3	6	13090	26180	57	227	60	78
SRCAG 1400x1010 - 1000x1410	1,4140	3	6	15270	30540	57	227	61	78
SRCAG 1200x1210	1,4520	3	6	15680	31360	57	227	61	78
SRCAG 1400x1210 - 1200x1410	1,6940	3	6	18300	36590	57	227	62	79
SRCAG 1400x1410	1,9740	3	6	21320	42640	57	227	63	80